

REV	DATE	DRAWN/CHKD	DESCRIPTION
F	11FEB03	GDM	ADDED M1-25
G	09FEB08	MJS	ADDED M1-15

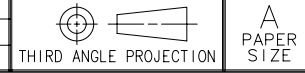

SOUTHCO PERFORMANCE GUIDELINES  
 THE PERFORMANCE GUIDELINES SHOWN ON THIS PAGE ARE SUPPLIED AS A GENERAL GUIDE ONLY, AS CONDITIONS VARY WITH EACH APPLICATION AND METHOD OF INSTALLATION. STRENGTH DATA GIVEN IS FOR FAILURE OF THE PRODUCT OR FOR SUFFICIENT DEFORMATION TO MAKE PRODUCT INOPERABLE. NO SAFETY FACTOR HAS BEEN APPLIED IT IS RECOMMENDED THAT THE USER REQUEST A PRODUCT SAMPLE FOR TESTING TO DETERMINE THE SUITABILITY OF THE PRODUCT FOR THE PURPOSE INTENDED AND USER'S PARTICULAR APPLICATION.

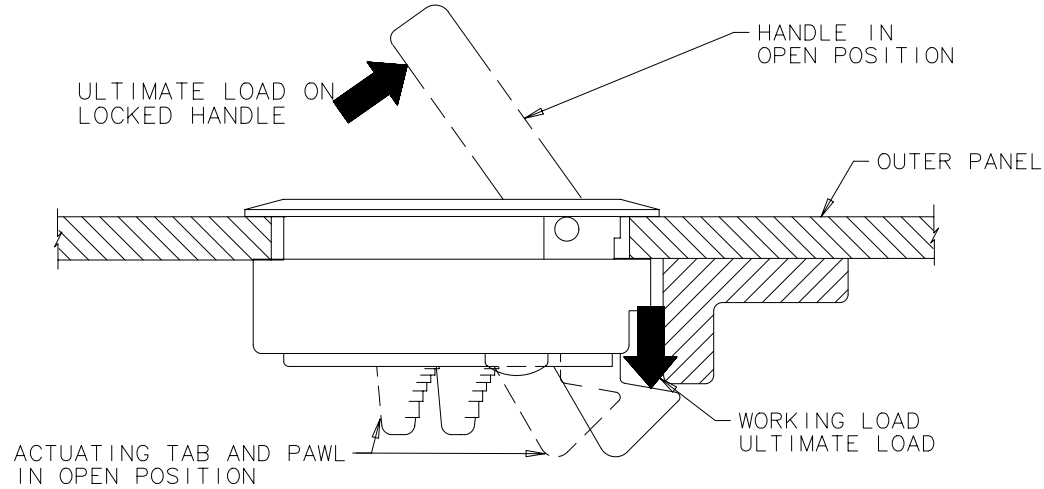

PART NUMBER	MOUNTING SCREW SIZE	MAX RECOMMENDED WORKING LOAD <sup>Ⓐ</sup>	AVERAGE ULTIMATE LOAD <sup>Ⓑ</sup>	MAX RECOMMENDED TIGHTENING TORQUE ON MOUNTING SCREW	AVERAGE ULTIMATE LOAD ON LOCKED HANDLE (LOCKABLE VERSION ONLY) <sup>Ⓒ</sup>
M1- <sup>4</sup> / <sub>6</sub> X M1- <sup>4</sup> / <sub>6</sub> X-1 M1- <sup>4</sup> / <sub>6</sub> X-7	M5	270 N (60 lbf)	445 N (100 lbf)	2.8 Nm (25 lbf in)	90 N (20 lbf)
M1- <sup>4</sup> / <sub>6</sub> X-8		835 N (187 lbf)	1265 N (284 lbf)		2520 N (557 lbf)
M1-25- <sup>4</sup> / <sub>6</sub> X-X8		1035 N (232 lbf)	1530 N (344 lbf)		1580 N (355 lbf)
M1-15- <sup>4</sup> / <sub>6</sub> X-8	6-32	545 N (122 lbf)	806 N (181 lbf)	1 Nm (8.8 lbf·in)	--

- Ⓐ WORKING LOAD is the maximum recommended load at which the product continues to function properly.
- Ⓑ ULTIMATE LOAD is the load that causes excessive pawl deformation, which renders the product inoperable.
- Ⓒ AVERAGE ULTIMATE LOAD ON LOCKED HANDLE is the load which is necessary to force open the handle when locked.