

# southco®

PROPRIETARY ITEM - EXCEPT FOR USES EXPRESSLY GRANTED IN WRITING INFORMATION DISCLOSED HEREON IS CONFIDENTIAL AND ALL RIGHTS PATENT AND OTHERWISE ARE RESERVED BY SOUTHCO, INC.

## C3 SCREW MOUNT GRABBER™ CATCH WITH HEAVY DUTY KEEPER

DATE	DRAWN	CHKD	SCALE
13MAY1994	LBZ		1:1

DRAWING NUMBER

J-C3-8

REV	DATE	DRAWN/CHKD	DESCRIPTION	ITEM	PART NUMBER	MATERIAL	FINISH	PULL-UP FORCE
A	06FEB95	MSB/	PRN: C3-75	ASSEMBLY	C3-803	-	-	13N (3 LBS)
B	31OCT98	JGK/	PRN: C3-143	ASSEMBLY	C3-805	-	-	22N (5 LBS)
C	03MAR2000	KPL/	PRN: PC3-154	ASSEMBLY	C3-810	-	-	44N (10 LBS)
D	24MAR2004	AAB/RLR	PRN: P2004-0308	RIVET	-	ALUMINUM	NATURAL	-
E	14DEC2005	RLR/MJS	PRN: P2005-1775	HOUSING	-	PC/ABS	BLACK	-
F	16OCT2009	ACH/MJS	PRN: P2009-1204	SPRING	-	302 STAINLESS STEEL	SEE NOTE E	-
				KEEPER	-	MINERAL FILLED NYLON	BLACK	-
				SPRING SUPPORT	-	GLASS FILLED NYLON	BLACK	-
				SUPPORT ROD	-	GLASS FILLED NYLON	BLACK	-
				PAWL	-	GLASS FILLED NYLON	BLACK	-

ALL DIMENSIONS WITHOUT TOLERANCES ARE FOR REFERENCE ONLY.

THIRD ANGLE PROJECTION

A4 PAPER SIZE

ASSEMBLY PART NUMBER	CATCH	KEEPER
C3-803	C3-12-03	C3-77
C3-805	C3-12-05	C3-77
C3-810	C3-12-10	C3-77

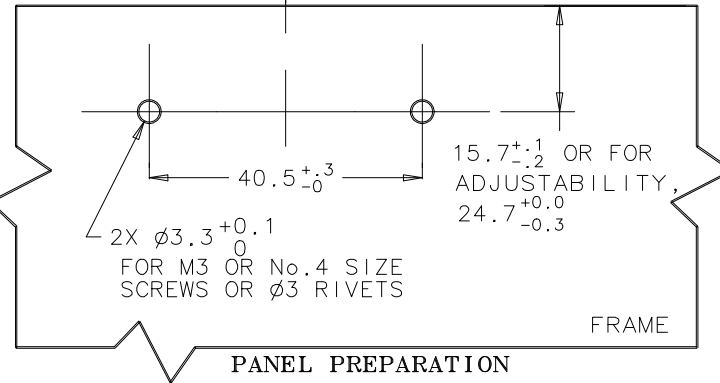
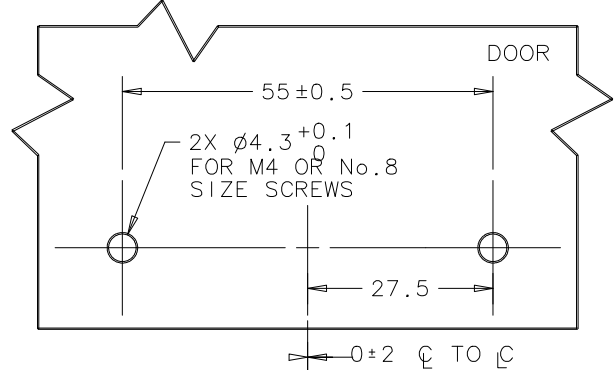
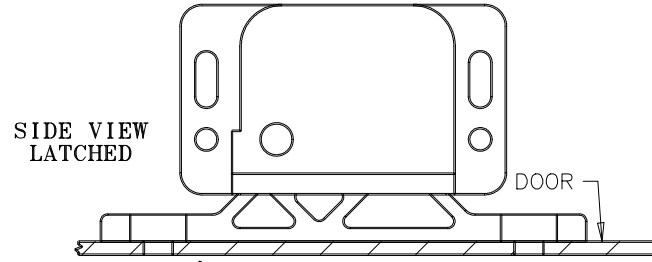
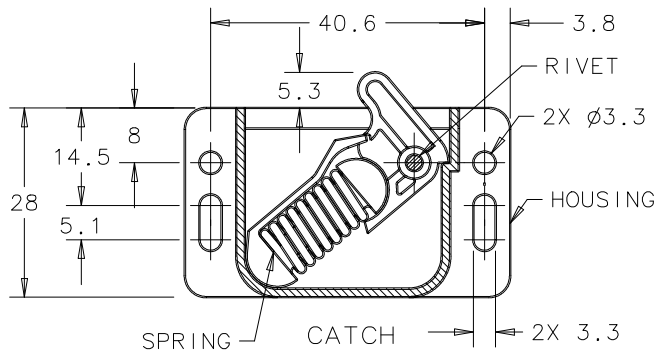
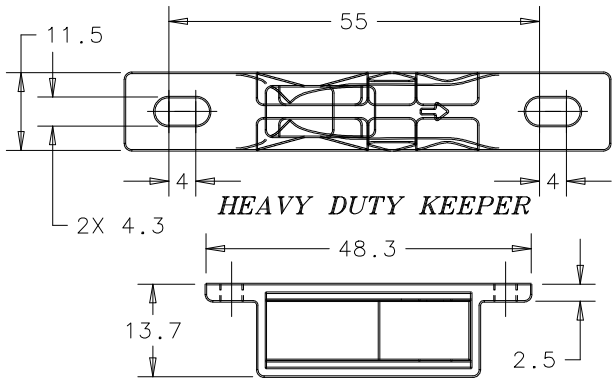
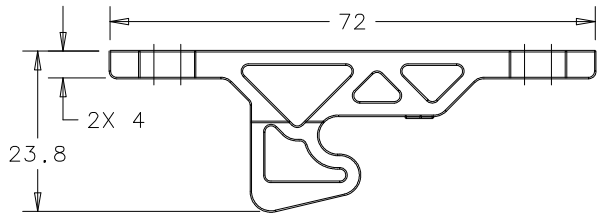

- PACKAGING NOTES:
- CATCH AND KEEPER SHIPPED SEPARATELY, BULK.
  - FOR CATCH AND KEEPER PACKAGED ONE PER BAG, ADD -P TO PART NUMBER. EXAMPLE: C3-803-P.
  - ADD A "-W" FOR ASSEMBLIES WITH ALL WHITE COMPONENTS. EXAMPLE: C3-810-W
  - MATERIAL FOR WHITE KEEPER WILL BE GLASS REINFORCED NYLON.
  - SPRING FINISH:  
 C3-803 = PASSIVATED, BLUE ORGANIC COATING  
 C3-805 = PASSIVATED  
 C3-810 = PASSIVATED, BLACK OXIDE

- INSTALLATION INSTRUCTIONS:
- MOUNT CATCH TO FRAME.
  - ORIENT KEEPER TO LATCH, MOUNT TO DOOR AND ADJUST FOR SMOOTH LATCHING.

