



Copie non contrôlée

Ce dessin ne doit pas être utilisé pour des fins de production

Uncontrolled copy

Do not use this drawing for manufacturing purposes

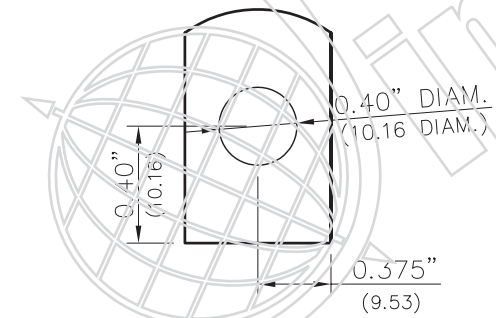
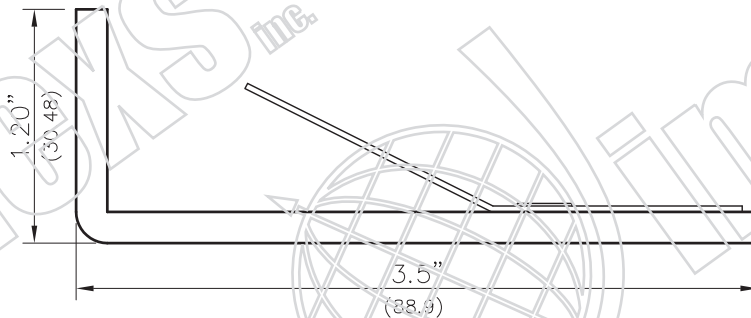
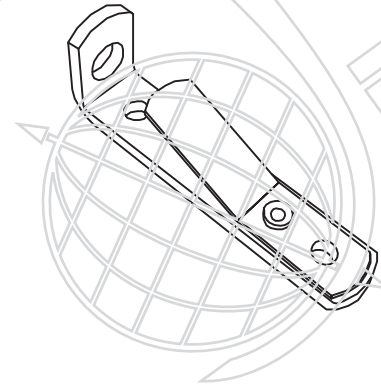
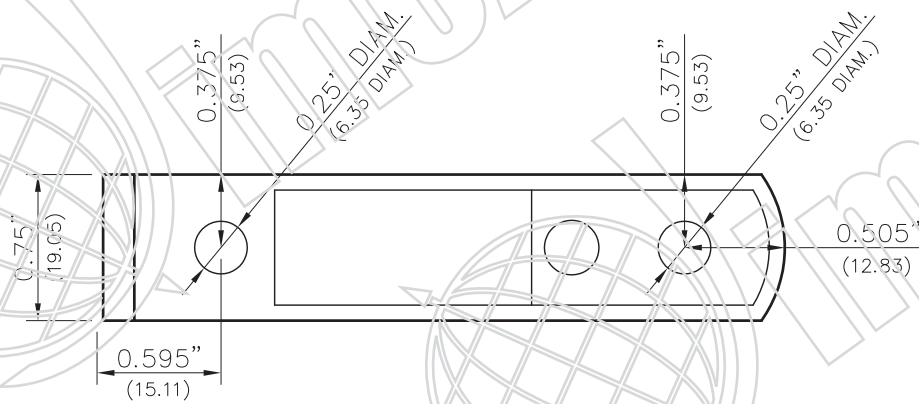

NUMERO DE PIÈCE/PART NUMBER		DESCRIPTION	
230-501		GUIDE DE TIGE/ROD GUIDE	
DESSIN PAR/DRAWING BY	MATÉRIEL/MATERIAL	FINI/FINISH	
S.TARDIF	ACIER/STEEL	ZINC	
TEL: (450) 464-9999/1-866-447-5656 FAX: (450) 464-9992/1-866-447-5625 JIMEXS.COM / INFO@JIMEXS.COM	DATE	FEUILLE/SHEET	ÉCHELLE/SCALE
	25/01/08	1/1	NAE

