

NOTE : MÉCANISME RIVETÉ / RIVETED MECANISM

# PCE / PART #	# CLÉ / KEY #	# PCE / PART #	# CLÉ / KEY #
226-001	CH501	226-006	CH506
226-002	CH502	226-007	CH507
226-003	CH503	226-008	CH508
226-004	CH504	226-009	CH509
226-005	CH505	226-010	CH510

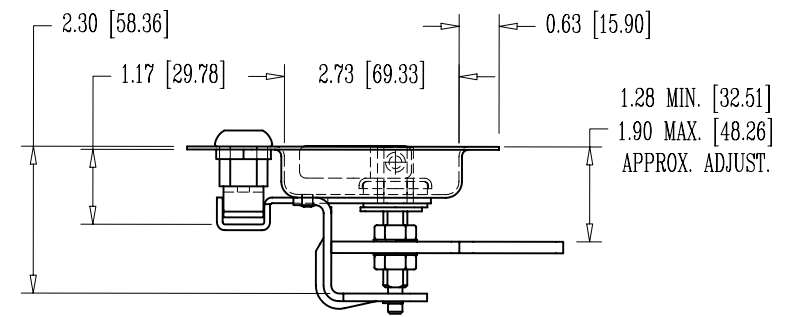

NUMERO DE PIÈCE/PART NUMBER	DESCRIPTION				
226-001	SERRURE ENCASTRÉE EN T / RECESSED FOLDING T-HANDLE				
DESSIN PAR/DRAWING BY	MATÉRIEL/MATERIAL		FINI/FINISH		
Y. DAGENAI	S/S 304		POLI / POLISHED		
JIMEXS.COM / INFO@JIMEXS.COM	DATE	FEUILLE/SHEET	ÉCHELLE/SCALE	SIZE	PROJECTIONS
	06/11/2003	1/1	1=3	A	

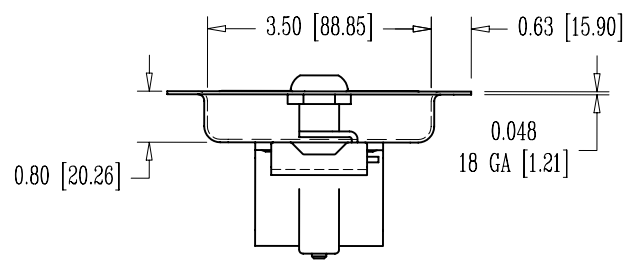